



KKB Engineering Berhad (26495-D)



**SUBMERGED
ARC WELDED
(SAW) TUBULAR
PILES**



CONTENTS



RANGE OF SPIRAL WELDED STEEL PILE SIZES	2
SPIRAL WELDED STEEL PILE – Manufacturing Process, Production and Control	3
RANGE OF SECTIONAL WELDED STEEL PILE SIZES	4
SECTIONAL WELDED STEEL PILE – Manufacturing Process, Production and Control	5
PRODUCT SPECIFICATION	6
TYPICAL DETAIL OF STEEL PILE JOINTINGS	7
TYPICAL DETAIL OF PILE SHOES	8
OTHER PRODUCTS & SERVICES	9

RANGE OF SPIRAL WELDED STEEL PILE SIZES/ WALL THICKNESSES

Wall Thicknesses	(inch)	0.2	0.3	0.4	0.5	0.6	0.6	0.7	0.8	0.9	0.9	1
	(mm)	6	8	10	12	14	16	18	20	22	24	25
Diameter:												
(inch)	(mm)											
20	500											
24	600											
28	700											
32	800											
36	900											
40	1000											
44	1100											
48	1200											
52	1300											
56	1400											
60	1500											
80	2000											
100	2500											

Spiral Welded Steel Pipe

- Manufacturing Process, Production and Control



SPRAL FORMING MILL

- a. Hot rolled coils of top quality produced under strict specifications are used.
- b. Internal / External Welding: Submerged Arc Welding Method.

Welded seams of spirally-welded pipes are along its circumference. Therefore, the accuracy of straightness and roundness is guaranteed. Consequently, a correction of bend is not necessary.

HYDROSTATIC PRESSURE TEST

Pipes are subjected to hydrostatic pressure tests which are conducted by remote valve control and automatically recorded.

PIPE-END BEVELLING

Pipe ends are bevelled to all desired specifications.

PIPE CUTTING

Pipes are automatically cut to any desired length.

END PREPARATION

Various types of flanges, collars or other attachments are available according to customer's specification.

FINAL INSPECTION

Surface and dimensions of pipes are carefully inspected prior to protective coating applications.

SURFACE PREPARATION

Steel Grit Blasting - Prior to coating / lining applications, pipes are cleaned externally & internally by an automated blasting machine.

FINISHED PRODUCTS

EXTERNAL COATING & INTERNAL LINING

Non-Destructive Testing (NDT)

1. Radiography Test
 2. Ultrasonic Test
 3. Dye Penetrant Test (DP)
- (As per Client's Requirement)

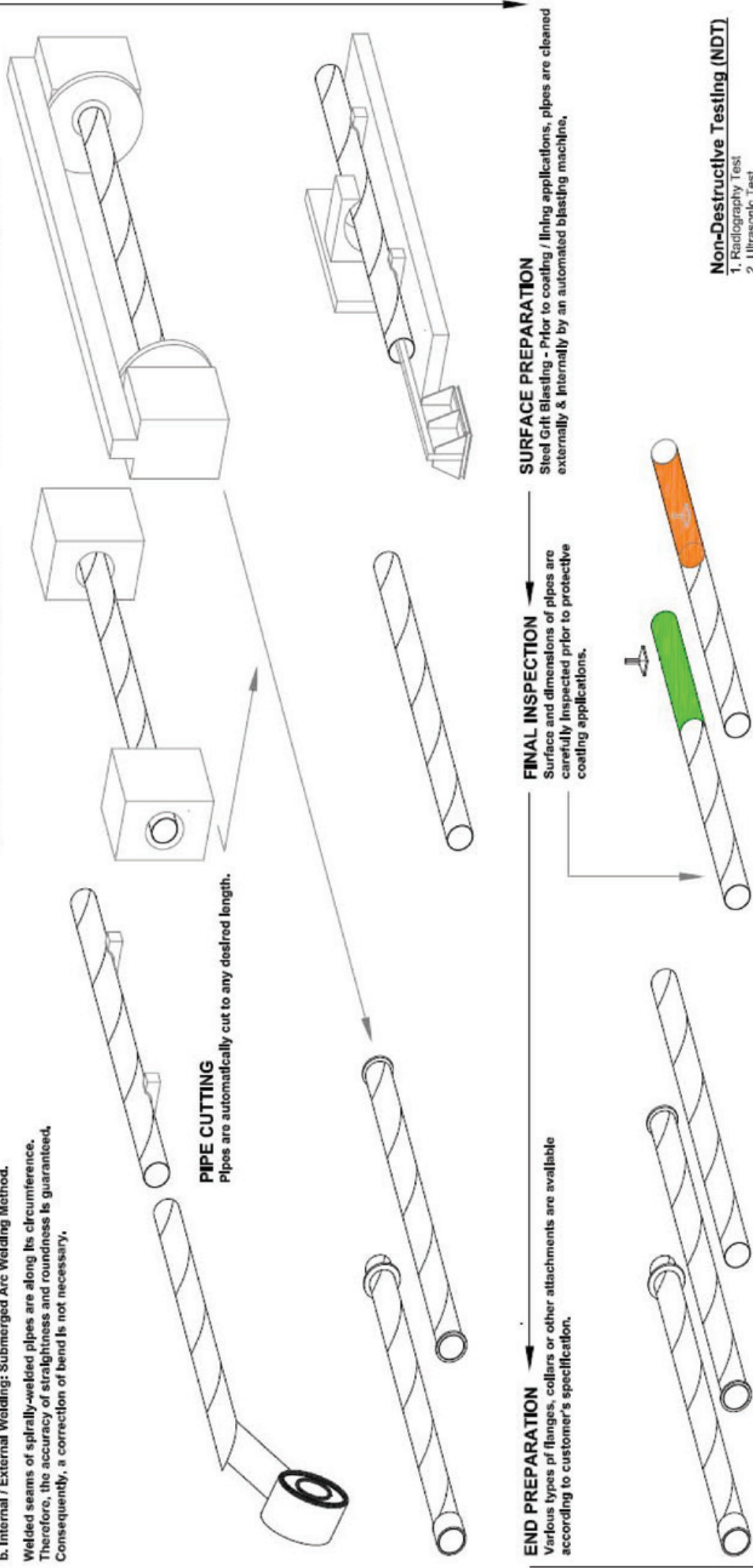

RANGE OF SECTIONAL WELDED STEEL PILE SIZES / WALL THICKNESSES

Wall Thicknesses:	(inch)	0.2	0.3	0.4	0.5	0.6	0.6	0.7	0.8	0.9	0.9	1
	(mm)	6	8	10	12	14	16	18	20	22	24	25
Diameter												
(inch)	(mm)											
16	400											
20	500											
24	600											
28	700											
32	800											
36	900											
40	1000											
44	1100											
48	1200											
52	1300											
56	1400											
60	1500											
80	2000											
100	2500											

Sectional Welded Steel Pipe

- Manufacturing Process, Production and Control

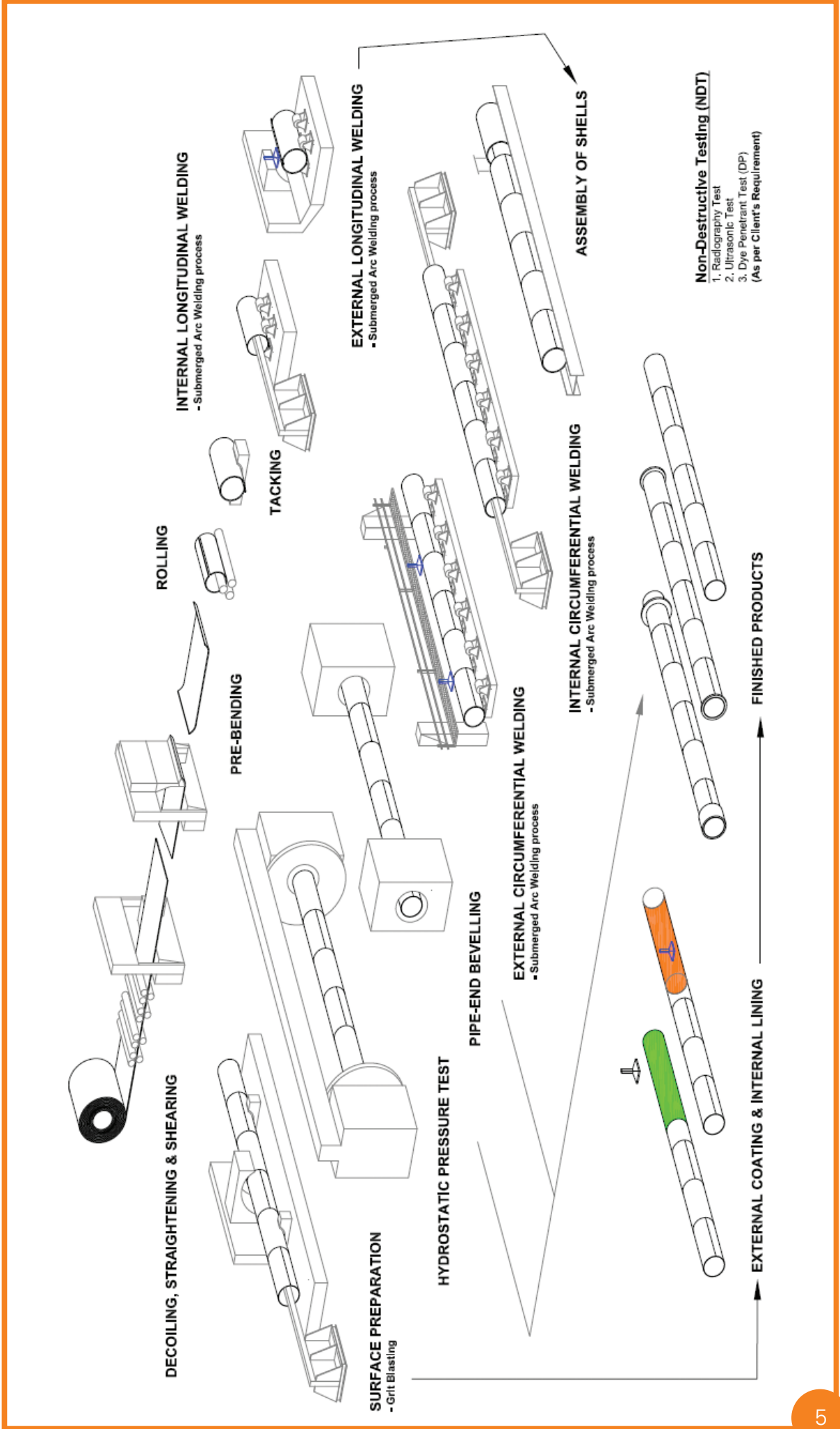

Product specification

Manufacturing Standards

- BS 3601
- ASTM A 252
- API 5L
- DIN 17100 - 1980

Surface Coating Systems

External Coating Selection:-

- Coal Tar & Asbestos Felt Wrap, AWWA C 203
- Coal Tar & Fibrous Glass Mat Wrap, AWWA C203
- Asphalt Coating, Dipping or Painting
- Epoxy Coating, AWWA C210
- Hot Dip Galvanizing
- Others as Per Client's Requirement



Typical Detail of Steel Pile Jointings

A. Expanded / Socketed

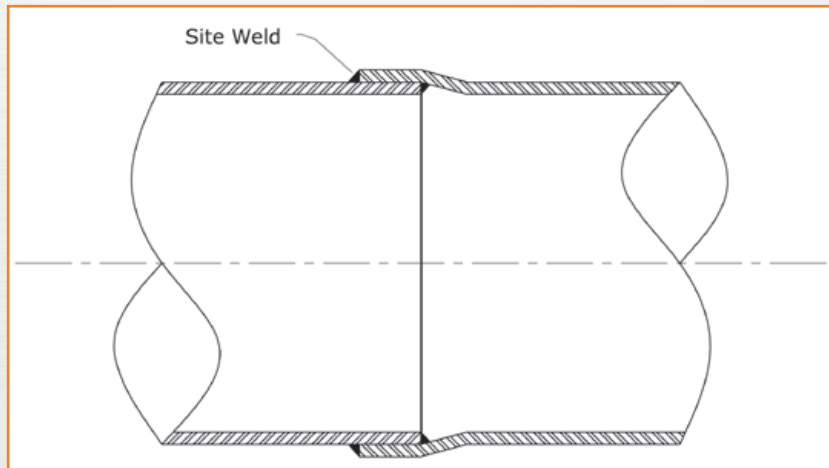

B. Sleeve & Backing Ring:

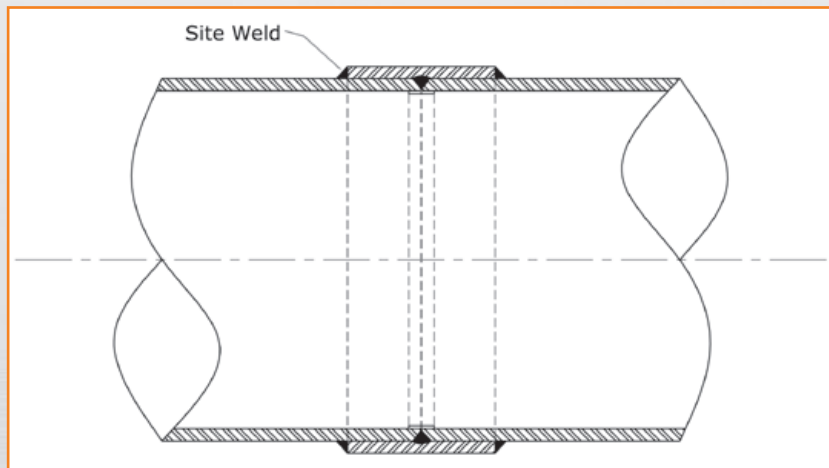

C. Beveled End Joint With Backing

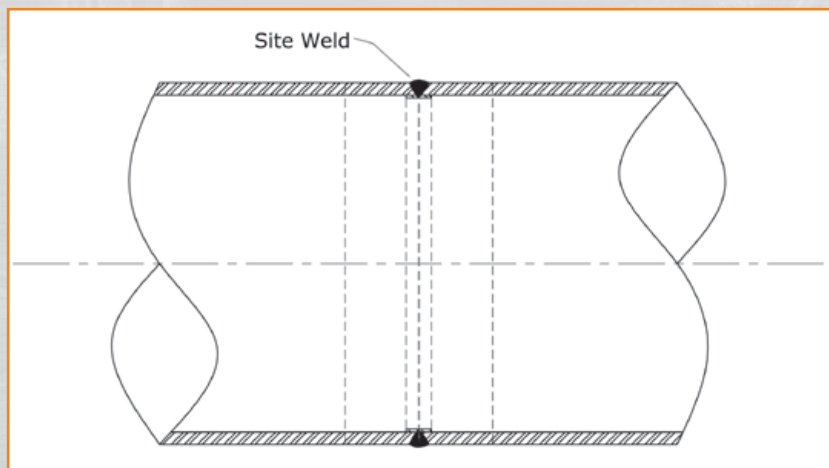

Typical Details of pile shoes

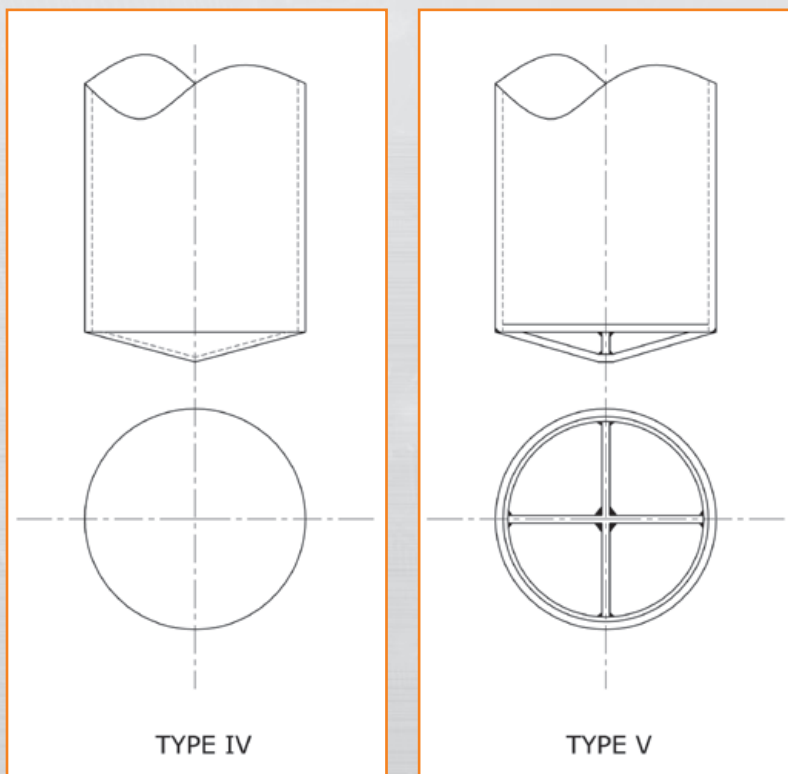
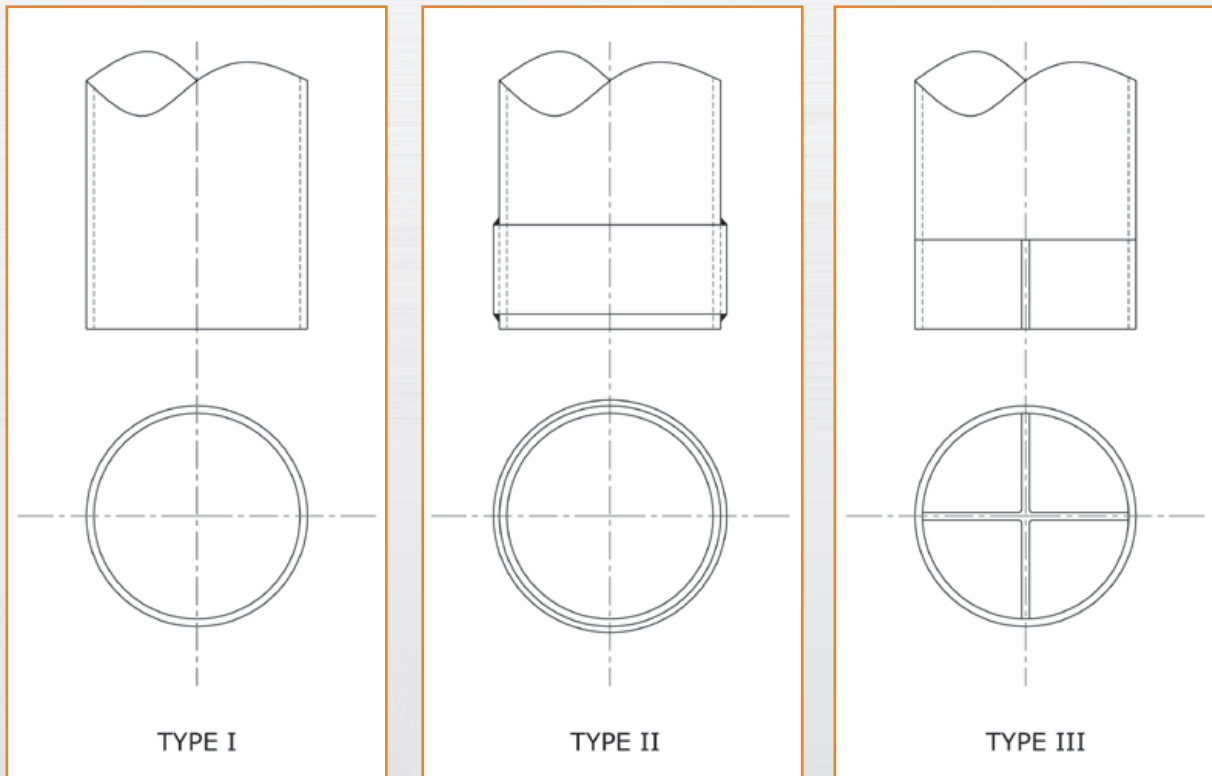

OTHER PRODUCTS & SERVICES:

- **Steel Fabrication** *(ISO 9001: 2008 & OHSAS 18001: 2007 Certified)*
- **Hot-Dip Galvanizing** *(ISO 9001: 2008 & OHSAS 18001: 2007 Certified)*
- **Steel Pipes Manufacturing** *(ISO 9001: 2008 & OHSAS 18001: 2007 Certified)*
- **LPG Cylinders Manufacturing** *(ISO 9001: 2008 & OHSAS 18001: 2007 Certified)*
- **Civil Construction** *(OHSAS 18001: 2007 Certified)*
- **uPVC Roofing Sheets Manufacturing**



KKB Engineering Berhad (26495-D)
Lot 865, Section 66, Jalan Kilang,
Bintawa Industrial Estate,
93450 Kuching, Sarawak, Malaysia.
Tel: (6) 082-333 877
Fax: (6) 082-331 152
E-Mail: kkbeb@kkbeb.com.my